



PRODUCT DATA SHEET

SikaFlow[®]-648

(formerly MFlow 648)

High-strength, high-flow, chemical resistant epoxy grout

PRODUCT DESCRIPTION

SikaFlow[®]-648 is a three-component epoxy resin-based precision grout used to secure critical equipment for proper alignment and transmission of static and dynamic loads. With carefully balanced physical properties and excellent resistance to chemical attack, elevated service temperatures, vibration and torque, SikaFlow[®]-648 is formulated for easy installation, with good flow characteristics suitable for pouring or pumping in thicknesses up to 6", low dust generation and soap and water clean-up.

SikaFlow[®]-648 is available in all regions of the world, supported by trained sales and technical personnel with experience in the specification and installation of epoxy grouts on every continent.

USES

SikaFlow[®]-648 is used for assembling and fixing of the following items:

- Precision alignment of compressors, generators, pumps, fans and electric motors
- Pour-back grouting for post-tensioning cables
- Sole plates
- Crane rail grouting
- Grouting of rolling, stamping, grinding, crushing, drawing and finishing mills, forging hammers and other equipment subject to high torque, impact and vibration
- Grouting of wind turbine tower bases
- Grouting of anchors, bars and dowels

Note: For off-shore wind turbine installations please refer to our Sikagrout-9000 series.

SikaFlow[®]-648 is typically used in the following industries:

- Chemical processing
- Oil and Gas extraction, refining, processing and distribution
- Power generation
- LNG production, storage and transmission
- Pulp and paper production
- Steel and aluminum manufacturing
- Mining
- Other heavy industry

CHARACTERISTICS / ADVANTAGES

- High early and ultimate strengths for rapid turnaround
- Low creep maintains equipment alignment
- Retains physical properties at elevated temperatures
- Low-dusting for added worker comfort and safety
- Very low shrinkage for full baseplate contact
- Excellent flowability with high bearing area for even load distribution
- Variable fill ratio for desired flowability
- Excellent adhesion to steel and concrete for optimum load transfer and vibration dampening
- High chemical resistance
- Excellent freeze/thaw resistance for equipment in low temperature service environments
- Resists water and chloride intrusion for use in wet and aggressive environments
- Resists impact and dampens torque to protect equipment and extend service life
- Extended working time
- Pumpable for maximum productivity if needed
- Durable bond to concrete and steel optimizes load transfer
- Globally available for consistent project results.

Product Data Sheet
SikaFlow[®]-648
March 2025, Version 02.03
02020200000002010

PRODUCT INFORMATION

Packaging	54.4 lb unit (0.4 ft ³ [0.01 m ³])*		
	Part A	Resin	5.5 lb (2.5 kg) pail
	Part B	Hardener	1.65 lb (0.75 kg) bottle
	Part C	Aggregate	47 lb (21.3 kg) bag
	*All components are packaged in a 6-gallon pail		
	216.6 lb unit (98.2 kg) (1.7 ft ³ [0.05 m ³])**		
	Part A	Resin	22.0 lb (10.0 kg) pail
	Part B	Hardener	6.6 lb (3.0 kg) bottle
	Part C	Aggregate	4 x 47 lb (21.3 kg) bags
	**All components packaged separately. May be ordered as a 3-bag unit, which will yield 1.4 ft ³ (0.04 m ³). When estimating project requirements, be sure to account for application variables		
Appearance / Color	Dark Grey		
Shelf Life	24 months if stored at below mentioned storage conditions.		
Storage Conditions	Store at ambient temperatures (60 to 80°F [16 to 27° C]), out of direct sunlight, in cool, dry conditions and clear of the ground on pallets protected from rainfall prior to application. The resin parts need to be protected from frost.		
Density	4-Bag Mix (6.55:1)	130 lb/ft ³ (2,084 kg/m ³)	ASTM C 905
	3-Bag Mix (4.92:1)	123 lb/ft ³ (1,971 kg/m ³)	
Flash Point	Part A (Resin)	419 °F (215 °C)	Pensky-Martens Closed Cup
	Part B (Hardener)	325 °F (163 °C)	

TECHNICAL INFORMATION

Abrasion Resistance	Better than concrete			
Impact Strength	Better than concrete			
Compressive Strength	Consistency (Fill Ratio)	7 Day Ambient	Post Cured	ASTM C 579, Method B
	4-Bag Mix (6.55:1)	14,500 psi (100 MPa)	16,000 psi (110 MPa)	
	3-Bag Mix (4.92:1)	14,000 psi (96 MPa)	15,000 psi (103 MPa)	

Product Data Sheet
SikaFlow®-648
March 2025, Version 02.03
020202000000002010



Time	50 °F	77 °F	90 °F	ASTM C 579, Method B
24 Hours	4,700 psi (32 MPa)	10,800 psi (75 MPa)	12,700 psi (88 MPa)	
2 Days	10,000 psi (69 MPa)	12,100 psi (83 MPa)	13,200 psi (91 MPa)	
3 Days	11,000 psi (76 MPa)	13,000 psi (90 MPa)	13,600 psi (94 MPa)	
4 Days	12,000 psi (83 MPa)	13,400 psi (92 MPa)	13,900 psi (96 MPa)	

*Filled 6.55:1, cured 24 hours at room temperature, post cured 16 hours at 140 °F, and conditioned 24 hours at test temperature.

Effective Bearing Area	1" Clearance	High (>85%)*	ASTM C 1339
	2" Clearance	High (>85%)*	
	*4-Bag Mix (6.55:1)		
Flexural Strength	4-Bag Mix (6.55:1)	4,700 psi (32 MPa)	ASTM C 580, 73 °F (23 °C)
	3-Bag Mix (4.92:1)	4,300 psi (30 MPa)	
Modulus of Elasticity in Flexure	4-Bag Mix (6.55:1)	2.5 x 10 ⁶ psi (17.2 GPa)	ASTM C 580, 73 °F (23 °C)
	3-Bag Mix (4.92:1)	2.3 x 10 ⁶ psi (15.9 GPa)	
Tensile Strength	4-Bag Mix (6.55:1)	2,000 psi (13.8 MPa)	ASTM C 307
	3-Bag Mix (4.92:1)	1,800 psi (12.4 MPa)	
Shear Strength	2,000 psi (14 MPa)*		Michigan DOT
	*Bond strength to steel at 73 °F (23 °C)		
Shrinkage	4-Bag Mix (6.55:1)	0.014	ASTM C 531
	3-Bag Mix (4.92:1)	0.031	
	unrestrained; linear, %		
Creep	Consistency (Fill Ratio)	400 psi (2.8 MPa) load	600 psi (4.1 MPa) load
	4-Bag Mix (6.55:1)	3.8 x 10 ⁻³	4.2 x 10 ⁻³
	3-Bag Mix (4.92:1)	4.0 x 10 ⁻³	4.9 x 10 ⁻³
Coefficient of Thermal Expansion	4-Bag Mix (6.55:1)	18 x 10 ⁻⁶ in/in/°F (32.2 x 10 ⁻⁶ cm/cm/°C)	ASTM C 531, 73–210° F (23–99° C)
	3-Bag Mix (4.92:1)	20 x 10 ⁻⁶ in/in/°F (36 x 10 ⁻⁶ cm/cm/°C)	
Flow Rate	Clearance	Back of Box	Full Plate Contact
	1"	11 min*	13 min*
	2"	4 min, 45 sec*	5 min*
	*4-Bag Mix (6.55:1)		

Product Data Sheet
SikaFlow®-648
March 2025, Version 02.03
020202000000002010



APPLICATION INFORMATION

Pot Life	Temperature	Time
	90 °F (32 °C)	50-60 min
	70 °F (21 °C)	90-120 min
	50 °F (10 °C)	120-150 min

BASIS OF PRODUCT DATA

Results may differ based upon statistical variations depending upon mixing methods and equipment, temperature, application methods, test methods, actual site conditions and curing conditions.

AVAILABILITY/WARRANTY

HANDLING AND TRANSPORT Usual preventive measures for the handling of chemical products should be observed when using this product, for example do not eat, smoke or drink while working and wash hands when taking a break or when the job is completed. Specific safety information referring the handling and transport of this product can be found in the Material Safety Data Sheet. For full information on Health and Safety matters regarding this product the relevant Health and Safety Data Sheet should be consulted.

Disposal of product and its container should be carried out according to the local legislation in force. Responsibility for this lies with the final owner of the product.

ENVIRONMENTAL, HEALTH AND SAFETY

This product is an article as defined in article 3 of regulation (EC) No 1907/2006 (REACH). It contains no substances which are intended to be released from the article under normal or reasonably foreseeable conditions of use. A safety data sheet following article 31 of the same regulation is not needed to bring the product to the market, to transport or to use it. For safe use follow the instructions given in the product data sheet. Based on our current knowledge, this product does not contain SVHC (substances of very high concern) as listed in Annex XIV of the REACH regulation or on the candidate list published by the European Chemicals Agency in concentrations above 0,1 % (w/w).

Product Data Sheet
SikaFlow®-648
March 2025, Version 02.03
02020200000002010

APPLICATION INSTRUCTIONS

Figure 1 - Regular Equipment

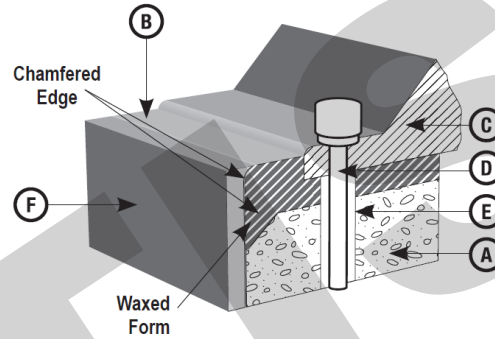

Key:

- A. Concrete Foundation
- B. Grout
- C. Equipment Base
- D. Anchor Bolt
- E. Anchor Bolt Sleeve Seal
- F. Form

Figure 2 - Engine with Oil Pan

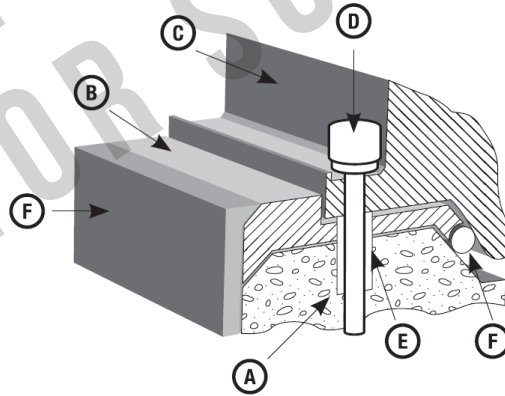

Figure 3 - Rail or Soleplate

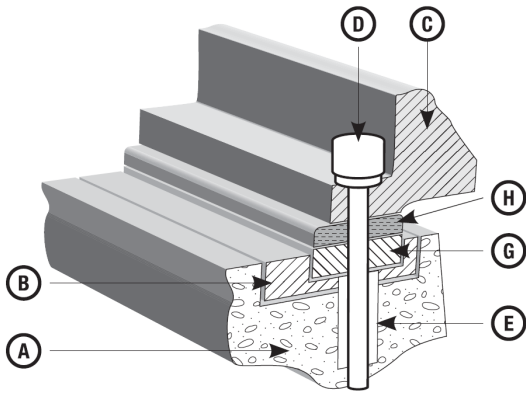

Figure 4 - Typical Rail with Expansion Joint Section

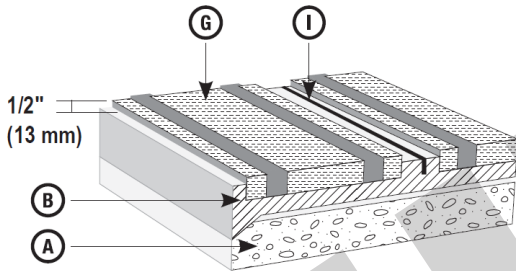
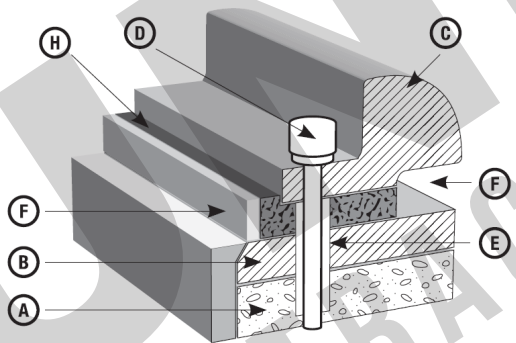

Figure 5 - Typical Epoxy Chock Application



NOTES ON INSTALLATION

- Do not add solvent, water, or any other material to the grout. Do not alter the resin or hardener proportions.
- Contact your local representative for a pre-job conference to plan the installation.
- For guidelines on specific anchor-bolt applications, contact Technical Service.
- Always use a head box when placing less than 1" (25 mm) depths.
- Substrate temperature must be greater than 50° F (10° C).

Product Data Sheet
SikaFlow®-648
March 2025, Version 02.03
02020200000002010

- Cold material will exhibit decreased flowability and reduced strength development.
- When using SikaFlow®-648 in post-tensioning anchorages, always use the standard aggregate load of 6.55:1.
- Minimum placement thickness is ½" (13 mm). Contact Technical Service before placing lifts more than 6" (152 mm) in depth.
- Chamfering the concrete edge helps reduce thermal cracking. Following proper installation procedures also reduce the potential for cracking.
- For professional use only; not for sale to or use by the general public.
- Make certain the most current versions of product data sheet and SDS are being used; visit <https://usa.sika.com/> to verify the most current versions.
- Proper application is the responsibility of the user. Field visits by Sika personnel are for the purpose of making technical recommendations only and not for supervising or providing quality control on the jobsite.

EQUIPMENT

1. If rust scale is present, abrade the bonding surfaces of the base to be grouted; it must be free of coatings, wax, grease, or scale. Mechanical methods, such as grinding or sanding, will suffice, but do not produce as high a bond strength as sandblasting.
2. Primer should be used ONLY when a long delay between cleaning and grouting could allow excessive rusting or contamination. If the base must be primed, use Sikadur-32 Hi-Mod.
3. The grout should come up at least ¼" (19 mm) onto the equipment. Protect the area above it with masking tape.
4. To facilitate cleanup, wax or cover all surfaces where the grout may splash or spill.

SURFACE PREPARATION

1. Cure the foundation until design strength of the concrete is achieved and foundation is dry. Use the recommended procedure according to ACI 351.1R, Grouting Between Foundations and Bases for Support of Equipment and Machinery.
2. The surface to be grouted must be clean, strong, and roughened to a CSP of 5–9, following ICRI Technical Guideline No. 310.2 to permit proper bond. Do not use a bushing hammer.
3. Chamfer the edge of the concrete 45 degrees to about a 2" (51mm) width.
4. If an anchor bolt sleeve is to be filled, be sure all water is removed. Use a siphon, vacuum pump, or rubber hose and bulb. Remove the residual moisture by either forced air or evaporation.
5. Seal the anchor bolt hole with felt, foam rubber, or other means.
6. Cover all shims and leveling screws with putty or clay to keep the grout from adhering. Use model clay, glazing putty, or anything with a putty consistency that will stick but not harden. Shims or jack pockets may be

- formed with wood, and forms filled with damp sand.
- 7. Remove shims or jack screws after the grout cures.
- 8. Shade the foundation from direct sunlight for at least 24 hours before and 48 hours after grouting.

MIXING

1. Aggregate must be completely dry.
2. Precondition all components to 70° F (21° C) for 24 hours before using.
3. Pour the hardener (Part B) into a pail of grout resin (Part A) and stir by hand with a spatula or paint stir paddle until well mixed to a uniform amber color.
4. Pour the mixture into a horizontal shaft mortar mixer or a Kol type mixer without delay.
5. Add the grout aggregate, one bag at a time, and mix only until aggregate is completely wetted out to avoid air entrapment. The first batch may be slightly less fluid than later batches because some of the resin is retained on the walls of the mixer. Withholding ½–1 bag of aggregate from the first batch of a full unit will compensate for lost resin. Note: always add aggregate to the mixer after the premixed liquids have been poured in.

Temperature	1.7 ft ³ unit very thin pours or very long distance	Standard pours
> 90° F (> 32° C)	—	—
70 to 90° F (21 to 32° C)	Up to ½ bag	—
50 to 70° F (10 to 21° C)	½ to 1 bag	½ bag

APPLICATION

Lengths of metal strapping laid in the formwork prior to placing may be necessary to assist grout flow over large areas and in compacting and eliminating air pockets. Have sufficient manpower, materials and tools to make mixing and placing rapid and continuous. Where grout must flow some distance, make the initial batch slightly more fluid or flowable than required; this lubricates the surfaces and avoids blockage of the grout that follows. The grout shall be poured continuously and from one side only, to avoid entrapment of air while grouting. Maintain a constant hydrostatic head, preferably of at least 4". On the side where the grout has been poured, allow 4" clearance between the side of the form and the base plate of the machine. On the opposite side allow 2"-4" clearance between the formwork and the base plate. Due to differences in temperature between the grout under the base plate, and exposed shoulders that are subject to more rapid temperature changes, debonding and / or cracking can occur. Avoid shoulders wherever possible. If shoulders are required, they should be firmly anchored with reinforcing to the substrate to prevent debonding. Make sure grout fills the entire space to be grouted and remains in contact with the plate throughout the entire grouting placement.

Product Data Sheet
SikaFlow®-648
March 2025, Version 02.03
02020200000002010

Note: Do not use vibrator for placing the grout!

COLD-WEATHER CURING

For cold weather grouting use SikaFlow 640 Accelerator. Refer to the SikaFlow 640 Accelerator PDS.

1. The foundation and the equipment base will probably be cooler than room temperature unless room temperature has been constant for some time. Use the foundation and engine temperature, therefore, in estimating cure time.
2. Temperatures vary so radically, day vs. night, atmospheric vs. metal surface, that field judgment must still be used as the final measure. Cured grout should have a solid, almost metallic feel when struck with a hammer. Be sure to check as close to the base of the equipment as possible.

HOT-WEATHER GROUTING

1. Special care must be exercised when grouting at elevated temperatures, to reduce risks of premature hardening and subsequent cracking.
2. If the packaged grout is above 90° F (32° C), chill the sealed pails of grout resin in a tub of ice or cover the pails with water-soaked burlap to cool the grout to 70° F (21° C).
3. Provide shade from direct sunlight for at least 24 hours before and 48 hours after grouting.

COLD-WEATHER GROUTING

1. Temperatures below 60° F (16° C) make the grout stiff and hard to handle and significantly increase the cure time. The baseplate and foundation may be much cooler than room temperature. In cold weather, store materials in a warm place. For best handling, the temperature of the grout components and mixing equipment should be at least 70° F (21° C).
2. When baseplate and foundation temperatures (measured by a contact thermometer) are less than 50° F (10° C), heating of the area may be necessary.
3. If heating is required, erect an enclosure around the equipment and foundation to be grouted. Forced air or infrared heaters may be used to obtain the necessary heat to increase the baseplate and foundation temperatures to 50 to 70° F (10 to 21° C). Avoid local hot spots. Apply heat 1–2 days in advance of grouting to achieve uniform baseplate and foundation temperatures. Avoid exposure to exhaust from heating equipment. Remove heat during grout placement.
4. For temperatures from 40 to 50° F (4 to 10° C), consider using SikaFlow 640 Grout Accelerator to accelerate strength development.

CLEANING OF TOOLS

After the pour is complete, remove uncured epoxy from the mixer, wheelbarrow and tools with soap and water or a citrus degreaser. Cured material can only be removed mechanically.



OTHER RESTRICTIONS

See Legal Disclaimer.

LEGAL DISCLAIMER

- KEEP CONTAINER TIGHTLY CLOSED
- KEEP OUT OF REACH OF CHILDREN
- NOT FOR INTERNAL CONSUMPTION
- FOR INDUSTRIAL USE ONLY
- FOR PROFESSIONAL USE ONLY

Prior to each use of any product of Sika Corporation, its subsidiaries or affiliates ("SIKA"), the user must always read and follow the warnings and instructions on the product's most current product label, Product Data Sheet and Safety Data Sheet which are available at usa.sika.com or by calling SIKA's Technical Service Department at 1-800-933-7452. Nothing contained in any SIKA literature or materials relieves the user of the obligation to read and follow the warnings and instructions for each SIKA product as set forth in the current product label, Product Data Sheet and Safety Data Sheet prior to use of the SIKA product.

SIKA warrants this product for one year from date of installation to be free from manufacturing defects and to meet the technical properties on the current Product Data Sheet if used as directed within the product's shelf life. User determines suitability of product for intended use and assumes all risks. User's and/or buyer's sole remedy shall be limited to the purchase price or replacement of this product exclusive of any labor costs. **NO OTHER WARRANTIES EXPRESS OR IMPLIED SHALL APPLY INCLUDING ANY WARRANTY OF MERCHANTABILITY OR FITNESS FOR A PARTICULAR PURPOSE. SIKA SHALL NOT BE LIABLE UNDER ANY LEGAL THEORY FOR SPECIAL OR CONSEQUENTIAL DAMAGES. SIKA SHALL NOT BE RESPONSIBLE FOR THE USE OF THIS PRODUCT IN A MANNER TO INFRINGE ON ANY PATENT OR ANY OTHER INTELLECTUAL PROPERTY RIGHTS HELD BY OTHERS.**

Sale of SIKA products are subject to the Terms and Conditions of Sale which are available at <https://usa.sika.com/en/group/SikaCorp/termsandconditions.html> or by calling 1-800-933-7452.

Sika Corporation
201 Polito Avenue
Lyndhurst, NJ 07071
Phone: +1-800-933-7452
Fax: +1-201-933-6225
usa.sika.com



Product Data Sheet
SikaFlow®-648
March 2025, Version 02.03
02020200000002010

7 / 7

SikaFlow-648-en-US-(03-2025)-2-3.pdf

BUILDING TRUST

