

# Submittal Package

PERMINATOR 10 and 15 Mil Underslab Vapor Barrier



QUALITY | SERVICE | INTEGRITY

**W. R. MEADOWS®**

A Family Company Since 1926

800-342-5976

[www.wrmeadows.com](http://www.wrmeadows.com)

## Table of Contents:

### PERMINATOR 10 and 15 Mil Underslab Vapor Barrier

PERMINATOR

Product Data Sheet

PERMINATOR

Safety Data Sheet

PERMINATOR

Project Profile

PERMINATOR

Flyer

PERMINATOR

Guide Specification - 10 mil

PERMINATOR

Guide Specification - 15 mil

PERMINATOR

Installation Instructions

PERMINATOR

Radon Technical Bulletin

PERMINATOR

Sustainability Letter



**MasterFormat:**  
03 33 00  
07 26 16

**NOVEMBER 2024**  
(Supersedes September 2024)

## PERMINATOR®

### 10 and 15 Mil Underslab Vapor Barrier

#### DESCRIPTION

PERMINATOR underslab vapor barrier is a new generation of polyolefin-based resin/chemical technology. PERMINATOR provides the vapor barrier industry with a highly effective, economical choice for helping to reduce the penetration of moisture and water vapor through the slab into the structure, thereby helping to reduce fungus, mildew, and mold growth. PERMINATOR also helps reduce radon gas from entering the structure.

**New resin technology allows dramatically greater puncture resistance while maintaining one of the lowest perm ratings in the market.**

PERMINATOR is tough enough to withstand normal construction jobsite conditions and traffic. It will not crack, puncture, snag, split, or tear easily.

PERMINATOR prevents uncontrolled moisture from entering the slab allowing the slab to maintain the maximum slab moisture emission rate and relative humidity level as allowed by flooring manufacturer's specifications.

PERMINATOR is available in 10 mil and 15 mil thicknesses.

Installation is quick and easy. All joints/seams, both side and end, should be overlapped 6" (152.4 mm) and taped using 4" (101.6 mm) wide PERMINATOR TAPE from W. R. MEADOWS. PERMINATOR rolls fast and smoothly over level tamped soil or compacted fill.

#### USES

PERMINATOR underslab vapor barrier is primarily designed for underslab construction, where the soil has been tamped and leveled or compacted fill has been applied. Sheets are unrolled as is or cut to size and installed using the overlapping method. Overlaps are 6" (152.4 mm) wide and these seams are sealed using 4" (101.6 mm) wide PERMINATOR TAPE.

PERMINATOR can also be used as a protection course for waterproofing membranes. The desired sheet lengths are cut to size and retained at the top of the waterproofing membranes by PERMINATOR TAPE or TERMINATION BAR from W. R. MEADOWS.

PERMINATOR is suitable for use under radiant heating concrete slabs systems. The product can also be used in crawlspace applications.

#### FEATURES/BENEFITS

- Available in 10 mil and 15 mil thicknesses.
- Helps reduce the penetration of moisture and water vapor through the slab into the structure.
- Helps reduce fungus, mildew, and mold.
- Helps reduce radon gas from entering a structure.
- Resistant to methane gas.
- Tough enough to withstand normal construction jobsite conditions and traffic ... will not crack, puncture, snag, split, or tear easily.
- Installs quickly and easily over tamped grade ... no gravel, fill, or sand needed.
- PERMINATOR prevents uncontrolled moisture from entering the slab allowing the slab to maintain the maximum slab moisture emission rate and relative humidity level as allowed by flooring manufacturer's specifications.
- 10 or 15 mil thickness clearly marked on membrane for easy visual identification on jobsite.
- VOC content is 0 g/L.
- Made in America.

#### PACKAGING

10 mil: 14' wide (4.3 m), 210' long (64 m)

15 mil: 14' wide (4.3 m), 140' long (42.7 m)

\*Factory welds are available by special order if larger width rolls are required.

#### SPECIFICATIONS/STANDARDS

- Meets or exceeds all requirements of ASTM E1745 Class A, B & C.
- ACI 302.2R-22: Guide for Concrete Slabs that Receive Moisture Sensitive Flooring Materials makes a suggestion to use materials having 0.01 perms when flooring materials require protection lower than that determined by ASTM E1745. PERMINATOR 15 mil meets this requirement.

**CONTINUED ON REVERSE SIDE ...**

#### W. R. MEADOWS, INC.

P.O. Box 338 • Hampshire, IL 60140-0338  
Phone: 847/214-2100 • Fax: 847/683-4544  
1-800-342-5976  
www.wrmeadows.com • info@wrmeadows.com

HAMPSHIRE, IL / CARTERSVILLE, GA / YORK, PA  
FORT WORTH, TX / BENICIA, CA / POMONA, CA  
GOODYEAR, AZ / MILTON, ON / SHERWOOD PARK, AB

**TECHNICAL DATA**

Properties	PERMINATOR (10 Mil)	PERMINATOR (15 Mil)
Water Vapor Permeance ASTM E-96 Perms	0.0183	0.0063
Puncture Resistance ASTM D1709 Method B Grams	>3500	>3200
Tensile Strength ASTM E 154 Section 9 Lb. Force/Inch (kN/m)	52 (9.12)	70 (12.26)
Water Vapor Permeance After Wetting Out Drying Out and After Long-Term Soaking ASTM E154 Section 8 Perms	0.0219	0.0052
Water Vapor Permeance Resistance to Plastic Flow and Elevated Temperature ASTM E154 Section 11 Perms	0.0197	0.0067
Water Vapor Permeance Effect Low Temperature and Flexibility ASTM E154, Section 12 Perms	0.0212	0.0052
Water Vapor Permeance Resistance to Deterioration From Organisms and Substances in Contacting Soil ASTM E154, Section 13 Perms	0.0198	0.0052
Radon Transmittance (m/s) k124/02/95	$3.7 \times 10^{-8}$	$8.7 \times 10^{-9}$
Radon Coefficient (m2/s)	$9.4 \times 10^{-12}$	$3.3 \times 10^{-12}$

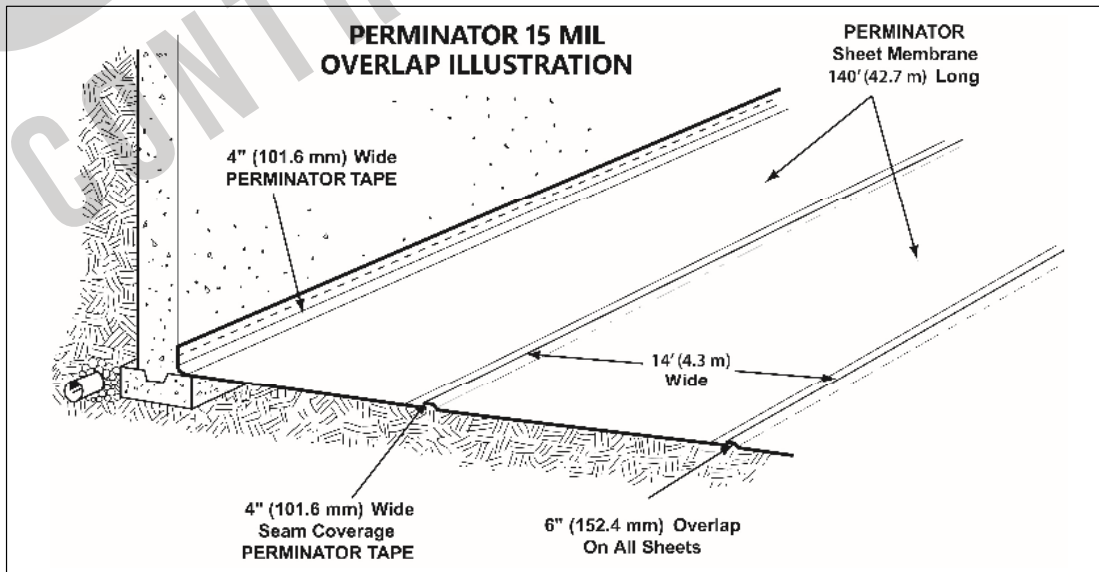

**APPLICATION**

**Surface Preparation** ... Level, tamp, or roll earth or granular material beneath the slab base as specified by supplied architectural drawings. Follow ASTM E-1643-10 (standard practice and procedure for installation of vapor retarder used in contact with earth or fill under concrete slabs). Reference American Concrete Institute (ACI) 302.1R-04: Chapter 4, Section 4.1.4 – Base Material for sub-grade preparation prior to placement of PERMINATOR.

**Horizontal Application** ... Unroll PERMINATOR over the area where the slab is to be poured. Cut to size if necessary. PERMINATOR should completely cover the pour area. All joints/seams, both side and end, should be overlapped 6" (152.4 mm) and taped using 4" (101.6 mm) wide PERMINATOR TAPE. (Note: The PERMINATOR TAPE area of adhesion should be free from dust, dirt, and moisture to allow maximum adhesion of the pressure-sensitive tape.)

The most efficient installation method includes placing PERMINATOR on top of the footing and against the vertical wall. This will sandwich PERMINATOR between the footing, vertical wall, and poured concrete floor. (See illustration on page 2.) This will help protect the concrete slab from external moisture sources once the slab has been placed.

Before placing concrete slab, make sure all penetrations, block outs, and damaged areas are repaired/addressed.

Numerous municipal building codes do not allow the placement of vapor barriers over the footing, due to breaking of the bond between the wall and footing. Although this is not an optimal application method, W. R. MEADOWS approves this alternate method when required by building code.

Figure 1 COLLAR

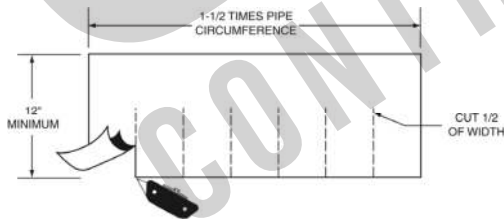

**Seal All Protrusions** ... Cut a slit around pipes, ductwork, rebar, and wire penetrations to place the initial layer of PERMINATOR. To further protect the concrete slab from external moisture sources, use a piece of PERMINATOR and place a collar around this as well.

1. Cut a piece of PERMINATOR a minimum width of 12" (304.8 mm). The length should be 1.5 times the pipe circumference. With a roofer's knife or scissors, cut "fingers" half the width of the film. See Figure 1.
2. Wrap around and tape the collar onto the pipe and completely tape fingers to the bottom layer of PERMINATOR, as shown in Figure 2.

In the event that PERMINATOR is damaged during or after installation, repairs must be made. Cut a piece of PERMINATOR large enough to cover any damage by a minimum overlap of 6" (152.4 mm) in all directions. Clean all adhesion areas of dust, dirt, and moisture. Tape down all edges using PERMINATOR TAPE.

NOTE: It is not necessary to overlay PERMINATOR with gravel or sand. PERMINATOR is tough enough to withstand normal construction abuse and traffic. Most flooring companies recommend the placement of the concrete slab directly on the vapor barrier. We agree, since this eliminates the potential for trapping moisture in a blotter-effect, causing it to resurface through the slab into the flooring systems. Consult local building codes and regulations, plus architectural and design firm guidelines, prior to application.

Figure 2: COLLAR INSTALLATION

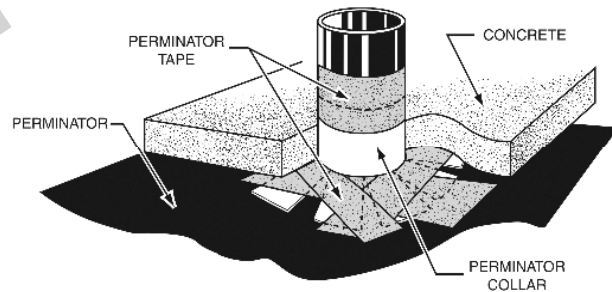

**Vertical Wall Application** ... Install MEL-ROL® waterproofing membrane or MEL-ROL LM liquid waterproofing membrane from W. R. MEADOWS according to installation instructions. While the membrane is still tacky, install PERMINATOR as a protective course over the applied waterproofing membrane. Using TERMINATION BAR with concrete nails or PERMINATOR TAPE at the termination of the waterproofing membrane is advisable in some applications. Supervised care must be taken during backfilling against the material so that it is not damaged or punctured. If damage occurs, patch using the techniques outlined previously. When applying PERMINATOR TAPE to foundation walls, MEL-PRIME™ adhesive from W. R. MEADOWS may be used to increase bond.

### ACCESSORIES

MEL-DRAIN™ rolled matrix drainage system is designed to remove moisture from around footings and to relieve hydrostatic head pressures. Several different versions are available.

MEL-ROL LM or POINTING MASTIC may be used for stakes, small pipe, and rebar penetrations. Cut PERMINATOR just big enough for the penetration. Liberally apply MEL-ROL LM or POINTING MASTIC around the penetration to keep the integrity of the PERMINATOR membrane intact. MEL-ROL LM can be applied by brush, roller, or sprayer. POINTING MASTIC can be applied by caulking gun or trowel.

PERMINATOR TAPE is a self-adhesive tape for use in sealing vapor barrier seams and attachment to footings, protrusions, etc. It is offered in 4" (10 cm) widths and roll lengths of 180' (55 m)/roll. It is packaged twelve rolls per carton. Coverage: One box of tape will adhere approximately 10 rolls of PERMINATOR.

TERMINATION BAR is provided in 10' (3 m) lengths to attach PERMINATOR to walls as a protection course for vertical surface waterproofing applications.

### PRECAUTIONS

PERMINATOR underslab vapor barrier does not negate the need for relief of hydrostatic heads. A complete drain tile system should be placed on the exterior of the footing and, in severe cases, on the interior of the footing as well. For maximum concrete performance and durability, the concrete floor slab design should provide for the lowest possible slump, yet assure complete hydration of the concrete. Maximum UV exposure time is 60 days. PERMINATOR can resist a maximum exposure temperature of 200° F (93° C) when used under radiant heating concrete slab systems. Refer to Safety Data Sheet for complete health and safety information.

For CAD details, most current data sheet, sustainability information, and SDS, visit [www.wrmeadows.com](http://www.wrmeadows.com).



#### LIMITED WARRANTY

W. R. MEADOWS, INC. warrants at the time and place we make shipment, our material will be of good quality and will conform with our published specifications in force on the date of acceptance of the order. Read complete warranty. Copy furnished upon request.

#### Disclaimer

The information contained herein is included for illustrative purposes only, and to the best of our knowledge, is accurate and reliable. W. R. MEADOWS, INC. cannot however under any circumstances make any guarantee of results or assume any obligation or liability in connection with the use of this information. As W. R. MEADOWS, INC. has no control over the use to which others may put its product, it is recommended that the products be tested to determine if suitable for specific application and/or our information is valid in a particular circumstance. Responsibility remains with the architect or engineer, contractor and owner for the design, application and proper installation of each product. Specifier and user shall determine the suitability of products for specific application and assume all responsibilities in connection therewith.

© W. R. MEADOWS 2024



# SAFETY DATA SHEET

SECTION 1: PRODUCT AND COMPANY IDENTIFICATION								
<b>Product:</b>	<b>PERMINATOR®</b>	<b>Part Number:</b>	<b>5242100</b>					
<b>Manufacturer:</b>	<b>W. R. MEADOWS, INC.</b>	<b>Address:</b>	300 Industrial Drive Hampshire, Illinois 60140					
<b>Telephone:</b>	(847) 214-2100	In case of emergency, dial (800) 424-9300 (CHEMTREC)						
<b>Revision Date:</b>	12/7/2023							
<b>Product Use:</b>	Vapor Retarder							
SECTION 2: HAZARDS IDENTIFICATION/EXPOSURE LIMITS								
HMIS								
Health	0	Product is classified as non-hazardous per OSHA 1910.1200. Perminator is defined by OSHA as an "article." A manufactured item that is formed to a specific shape or design during manufacture that does not release or result in exposure to a hazardous chemical under normal use conditions.						
Flammability	0							
Reactivity	0							
Personal Protection								
SECTION 3: HAZARDOUS COMPONENTS								
<b>Chemical Name:</b>	<b>CAS Number</b>	<b>% by Weight</b>	<b>SARA 313</b>	<b>Vapor Pressure (mm Hg@20°C)</b>	<b>LEL (@24°C)</b>			
1. Blown Polyethylene Film	Proprietary	100	No	N/A	N/A			
<i>N/A: Not Applicable</i>								
Under the reporting requirements of Section 313 of Title III of the Superfund Amendments and Reauthorization Act of 1966 (SARA) and 40 CFR Part 372, chemicals listed on the 313 List (40 CFR Part 373.65) are identified under the heading "SARA 313."								
SECTION 4: EMERGENCY AND FIRST AID PROCEDURES								
<b>EYE CONTACT:</b> Not expected to be an exposure route.								
<b>SKIN CONTACT:</b> Not Expected to be an exposure route.								
<b>INHALATION:</b> Not expected to be an exposure route.								
<b>INGESTION:</b> Not expected to be an exposure source.								
<b>MOST IMPORTANT SYMPTOMS/EFFECTS, ACUTE AND CHRONIC:</b> See Section Eleven for Symptoms/Effects.								
SECTION 5: FIRE AND EXPLOSIVES HAZARDS								
<b>FLASHPOINT:</b> Not applicable; product is a solid.								
<b>EXTINGUISHING MEDIA:</b> Water fog, foam, dry chemical.								
<b>CHEMICAL/COMBUSTION HAZARDS:</b> Carbon monoxide, carbon dioxide, and incomplete combustion products.								
<b>PRECAUTIONS/PERSONAL PROTECTIVE EQUIPMENT:</b> Avoid smoke inhalation. Use appropriate respiratory protection.								
SECTION 6: ACCIDENTAL RELEASE MEASURES								
<b>SPILL OR LEAK PROCEDURES:</b> Not applicable. Product is a solid.								
SECTION 7: HANDLING AND STORAGE								
<b>SAFE HANDLING PROCEDURES:</b> None.								
<b>SAFE STORAGE:</b> Prevent job-site damage.								
SECTION 8: EXPOSURE CONTROLS/PERSONAL PROTECTION								
	OSHA				ACGIH			
<b>Chemical Name:</b>	<b>PEL</b>	<b>PEL/CEILING</b>	<b>PEL/STEL</b>	<b>SKIN</b>	<b>TLV</b>	<b>TLV/CEILING</b>	<b>TLV/STEL</b>	<b>SKIN</b>
1. Blown Polyethylene	N/E	N/E	N/E	No	N/E	N/E	N/E	N/E
<i>N/E: Not Established</i>								
<b>ENGINEERING CONTROLS:</b> None required under normal use conditions.								
<b>PERSONAL PROTECTIVE EQUIPMENT:</b> None required under normal use conditions.								

**SAFETY DATA SHEET**

<b>Date of Preparation:</b> 12/7/23		<b>Page 2 of 2</b>	<b>5242100</b>
<b>SECTION 9: PHYSICAL AND CHEMICAL PROPERTIES</b>			
<b>BOILING POINT:</b> N/A	<b>VAPOR DENSITY:</b> N/A	<b>% VOLATILE BY VOLUME:</b> N/A	
<b>EVAPORATION RATE:</b> N/A	<b>pH LEVEL:</b> N/A	<b>% VOLATILE BY WEIGHT:</b> N/A	
<b>WEIGHT PER GALLON:</b> N/A	<b>PRODUCT APPEARANCE:</b> Green Film	<b>VOC CONTENT:</b> N/A	
<b>ODOR:</b> None	<b>ODOR THRESHOLD:</b> N/D	<b>MELTING/FREEZING POINT:</b> N/D	
<b>FLASH POINT:</b> See Section 5	<b>FLAMMABILITY:</b> See Section 5	<b>UEL/LEL:</b> N/D	
<b>VAPOR PRESSURE:</b> N/D	<b>RELATIVE DENSITY:</b> N/D	<b>SOLUBILITY:</b> N/D	
<b>PARTITION COEFFICIENT:</b> N/D	<b>AUTOIGNITION TEMPERATURE:</b> N/D	<b>DECOMPOSITION TEMPERATURE:</b> N/D	
<b>VISCOSITY:</b> N/D		<i>N/D: Not Determined</i>	
<b>SECTION 10: STABILITY/REACTIVITY</b>			
<b>STABILITY:</b> Stable.		<b>HAZARDOUS POLYMERIZATION:</b> Will not occur.	
<b>CONDITIONS AND MATERIALS TO AVOID:</b> None recognized.			
<b>HAZARDOUS DECOMPOSITION PRODUCTS:</b> None recognized.			
<b>SECTION 11: TOXICOLOGICAL INFORMATION</b>			
<b>EYE CONTACT:</b> Not anticipated to be an exposure route.			
<b>SKIN CONTACT:</b> Direct contact may cause slight skin irritation.			
<b>INHALATION:</b> Not anticipated to be an exposure route.			
<b>INGESTION:</b> Not anticipated to be an exposure route.			
<b>SIGNS AND SYMPTOMS:</b> None recognized.			
<b>AGGRAVATED MEDICAL CONDITIONS:</b> None recognized.			
<b>OTHER HEALTH EFFECTS:</b> None recognized			
<b>SECTION 12: ECOLOGICAL INFORMATION</b>			
<b>ECOTOXICITY:</b> N/E	<b>DEGRADABILITY:</b> N/E	<b>BIOACCUMULATIVE POTENTIAL:</b> N/E	
<b>SOIL MOBILITY:</b> N/E	<b>OTHER ADVERSE EFFECTS:</b> None Recognized	<i>N/E: Not Established</i>	
<b>SECTION 13: WASTE DISPOSAL INFORMATION</b>			
<b>WASTE DISPOSAL INFORMATION:</b> Product is classified as a non-hazardous waste.			
<b>SECTION 14: TRANSPORTATION INFORMATION</b>			
<b>HAZARDOUS/NON-HAZARDOUS MATERIAL:</b> Not regulated by DOT.			
<b>UN NUMBER:</b> None	<b>HAZARD CLASS:</b> N/A	<b>PACKING GROUP:</b> N/A	
<b>UN PROPER SHIPPING NAME:</b> N/A			
<b>ENVIRONMENTAL HAZARDS:</b> None recognized.			
<b>BULK TRANSPORTATION INFORMATION:</b> None.			
<b>SPECIAL PRECAUTIONS:</b> None.			<i>N/A: Not Applicable</i>
<b>SECTION 15: REGULATORY INFORMATION</b>			
<b>OTHER REGULATORY CONSIDERATIONS:</b> None recognized.			
<b>SECTION 16: OTHER INFORMATION</b>			
<b>PREPARATION DATE:</b>	12/7/2023		
<b>PREPARED BY:</b>	Dave Carey		

*The information contained herein is based on the data available to us and is believed to be correct. However, we make no warranty, expressed or implied regarding the accuracy of this data or the results to be obtained from the use thereof. We assume no responsibility for injury from the use of this product described herein.*



### W. R. MEADOWS, INC.

P.O. Box 338 • Hampshire, IL 60140-0338  
Phone: 847/214-2100 • Fax: 847/683-4544  
1-800-342-5976

www.wrmeadows.com • info@wrmeadows.com

HAMPSHIRE, IL / CARTERSVILLE, GA / YORK, PA  
FORT WORTH, TX / BENICIA, CA / POMONA, CA  
GOODYEAR, AZ / MILTON, ON / SHERWOOD PARK, AB



Project: Data Center  
Location: Santiago, Chile  
Contractor: DPC Construction  
Distributor: IMPC

Salesperson: Angel Cisneros  
Products: PERMINATOR,  
PERMINATOR TAPE  
Scope: 280,000 square feet



# W. R. MEADOWS®

## SEALTIGHT®

*A Family Company Since 1926*  
QUALITY...SERVICE...INTEGRITY

# W. R. MEADOWS, INC.

P.O. Box 338 • Hampshire, IL 60140-0338  
Phone: 847/214-2100 • Fax: 847/683-4544  
1-800-342-5976

www.wrmeadows.com • info@wrmeadows.com

HAMPSHIRE, IL / CARTERSVILLE, GA / YORK, PA  
FORT WORTH, TX / BENICIA, CA / POMONA, CA  
GOODYEAR, AZ / MILTON, ON / SHERWOOD PARK, AB

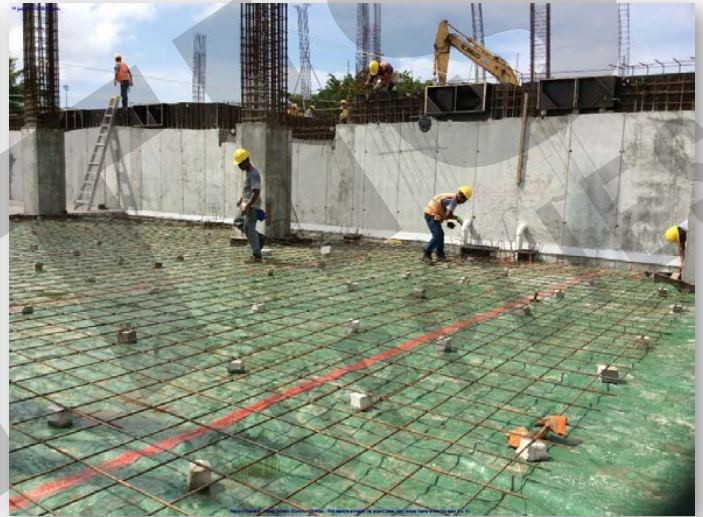

Project: Banco General Financial Campus  
Location: Panama City, Panama  
Contractor: Ingenieria R+M  
Salesperson: Angel Cisneros

Products: PERMINATOR,  
PERMINATOR TAPE  
Scope: 162,000 sq. ft.



# W. R. MEADOWS®

## SEALTIGHT®

*A Family Company Since 1926*  
QUALITY...SERVICE...INTEGRITY

# W. R. MEADOWS, INC.

P.O. Box 338 • Hampshire, IL 60140-0338  
Phone: 847/214-2100 • Fax: 847/683-4544  
1-800-342-5976

www.wrmeadows.com • info@wrmeadows.com

HAMPSHIRE, IL / CARTERSVILLE, GA / YORK, PA  
FORT WORTH, TX / BENICIA, CA / POMONA, CA  
GOODYEAR, AZ / MILTON, ON / SHERWOOD PARK, AB



**Project:** Johnson Middle School  
**Location:** Westminster, California, USA  
**Architect:** LPA  
**Contractor:** Tovey/Shultz Construction  
**Subcontractor:** Kar Construction

**Products:** MEL-ROL® LM  
PERMINATOR.  
PERMINATOR TAPE  
**Scope:** 45,000 sq. ft.



# PERMINATOR<sup>®</sup>

## Underslab

### Vapor Retarder/Barrier

Low perm rating + superior puncture resistance = the ultimate protection against water vapor



For lasting protection against moisture intrusion and potentially expensive flooring failures, choose a vapor retarder/barrier with one of the industry's lowest perm ratings and nearly the puncture resistance of others - PERMINATOR.

Low permeability, high strength and durability are all equally important selection and specification criteria for underslab vapor retarders/barriers. In fact, these characteristics are interdependent upon each other when it comes to preventing the migration of moisture into interior spaces. With **PERMINATOR**, you get the best of both world - superior puncture resistance coupled with one of the lowest perm ratings in the industry.

Proprietary technology enables **PERMINATOR** to significantly exceed the requirements of ASTM E1745 (0.1 perms), as well as the recommendation of ACI 302.2R which states a vapor barrier with a perm rating of 0.01 perms or less should be installed in areas where the requirements of ASTM E1745 are not sufficient to protect the floor. **PERMINATOR 15** product technology provides the entire building team with the lowest vapor permeance along with puncture resistance that is more than 45% tougher than required by ASTM E1745. In addition, **PERMINATOR** is an integral part of any radon mitigation system.

**W. R. MEADOWS backs the facts about PERMINATOR 15 technology with independent test results. Contact us for details - we'll supply the test results along with samples, data sheets, promotional literature and more.**

For more information on **PERMINATOR**, samples or literature, visit [wrmeadows.com](http://wrmeadows.com) or call 1-800-342-5976.

follow us:

- @wrmeadows
- facebook.com/wrmeadows
- w-r-meadows-inc
- wrmeadowsinc
- wrmeadowsinc
- #wrmeadows



PRINTED IN USA  
04/23-4M #55-5



**BELOW-GRADE VAPOR RETARDERS**

SECTION 07 26 16

SECTION 03 00 00

**BELOW-GRADE GAS RETARDERS**

SECTION 07 26 23

SECTION 03 00 00

Specifier Notes: This guide specification is written according to the Construction Specifications Institute (CSI) MasterFormat. The section must be carefully reviewed and edited by the architect or engineer to meet the requirements of the project. Coordinate this section with other specification sections and the drawings.

Specifier Notes: PERMINATOR 10-mil below-grade [vapor] [gas] retarder is a new generation of a polyolefin-based resin-chemical technology providing enhanced puncture resistance. PERMINATOR 10-mil performs as a water-vapor, methane and radon retarding membrane for underslab conditions. The specifier shall edit this specification to reflect the end use of PERMINATOR 10-mil as either a water vapor retarder **or** a below-grade radon and methane gas retarder based on the above-referenced MasterFormat Sections. Additionally, the specifier shall select the MasterFormat Section Number based on their location preference within the project documents. When specified in 07 26 16 and 07 26 23, coordination with Concrete specifications and drawings is recommended. Manufacturer's technical data sheets, standard details, Installation Guidelines and technical bulletins shall supplement the information contained herein.

## PART 1 GENERAL

## 1.01 SECTION INCLUDES

- A. Surface preparation.
- B. Application of an underslab membrane [vapor] [gas] retarder system.

## 1.02 RELATED SECTIONS

Specifier Notes: Edit the list of Related Sections as required for the project. Include additional sections for Work directly related to or connected with this specification.

- A. Section 03 30 00 – Cast-in-Place Concrete.
- B. Section 07 13 26 - Self-Adhering Sheet Waterproofing.
- C. Section 07 14 16 - Cold Fluid-Applied Waterproofing.
- D. Section 09 64 00 - Wood Flooring.
- E. Section 09 65 00 - Resilient Flooring.
- F. Section 31 20 00 Earth Moving.

## 1.03 REFERENCES

- A. ACI 302.2R - Concrete Slabs that Receive Moisture-Sensitive Flooring Materials—Guide.
- B. ASTM D1709 - Standard Test Methods for Impact Resistance of Plastic Film by the Free-Falling Dart Method.
- C. ASTM E96 - Standard Test Methods for Water Vapor Transmission of Materials.
- D. ASTM E154 - Standard Test Methods for Water Vapor Retarders Used in Contact with Earth Under Concrete Slabs, on Walls, or as Ground Cover.

07 26 16-1

Below-Grade [Vapor] [Gas] Retarders

- E. ASTM E1643 - Standard Practice for Selection, Design, Installation, and Inspection of Water Vapor Retarders Used in Contact with Earth or Granular Fill Under Concrete Slabs.
- F. ASTM E1745 - Standard Specification for Plastic Water Vapor Retarders Used in Contact with Soil or Granular Fill Under Concrete Slabs.
- G. ASTM F1249 - Standard Test Method for Water Vapor Transmission Rate Through Plastic Film and Sheeting Using a Modulated Infrared Sensor.
- H. K124/02/95 - Determination of Radon Transmittance.

#### 1.04 SUBMITTALS

- A. Comply with Section 01 33 00 - Submittal Procedures.
- B. Submit manufacturer's product data and application instructions.

#### 1.05 QUALITY ASSURANCE

- A. Use an experienced installer and adequate number of skilled personnel who are thoroughly trained and experienced in the application of the membrane retarder system.
- B. Obtain membrane retarder materials from a single manufacturer regularly engaged in manufacturing the product.
- C. Provide products which comply with all state and local regulations controlling use of volatile organic compounds (VOCs).

#### 1.06 PRECONSTRUCTION MEETING

- A. Preconstruction Meeting: Convene [one] [ ] week prior to commencing Work of this section, in accordance with Section [XX XX XX] - Project Meetings, and Section [XX XX XX] - membrane [vapor] [gas] retarder system.
- B. Review peripheral system tie-in conditions unrelated to the membrane retarder and confirm compatibility of all connecting systems. Ensure all peripheral systems are connected in a fully adhered manner.

#### 1.07 MOCKUPS

- A. Prior to start of the Work, apply membrane retarder system in accordance with manufacturers current technical data sheets, specifications, installation guidelines and details to demonstrate correct lapping and sealing to protrusions, adjoining construction and other termination conditions.
- B. Apply a typical 8 foot long by 8-foot wide (2.4 meters by 2.4 meters) representation of the membrane retarder system onto correctly prepared substrate, incorporating connections and interfaces with the following: MEP penetrations, vertical foundations and adjacent constructions. At architect's discretion, the mockup may be incorporated into the Work.

#### 1.08 DELIVERY, STORAGE, AND HANDLING

- A. Deliver materials to project site in manufacturer's original, unopened packaging, with labels clearly identifying the manufacturer and product name.
- B. Store materials in a clean, dry area in accordance with manufacturer's instructions.
- C. Protect materials during handling and application to prevent damage or contamination.

#### 1.09 ENVIRONMENTAL REQUIREMENTS

07 26 16-2 Below-Grade [Vapor] [Gas] Retarders

- A. Product is not intended for conditions subject to abuse or permanent exposure to the elements.
- B. Do not apply on frozen ground.

**PART 2 PRODUCTS**

**2.01 MANUFACTURER**

- A. W. R. MEADOWS, INC., PO Box 338, Hampshire, Illinois 60140-0338. (800) 342-5976. (847) 683-4500. Fax (847) 683-4544. Web Site www.wrmeadows.com.

**2.02 MATERIALS**

- A. 10-Mil Plastic [Vapor] [Gas] Retarder
  - 1. Below-grade [vapor] [gas] retarder manufactured of a new generation of polyolefin-based resin-chemical technology having the following properties:
    - a. Water-Vapor Permeance, ASTM E96: 0.0183.
    - b. Puncture Resistance, ASTM D1709, Method B: greater than 3500 grams.
    - c. Tensile Strength, ASTM E154, Section 9: 52 lb./Force/in. (9.12 kN/m).
    - d. Water-Vapor Permeance, After Wet-Out/Dry-Out and Long-Term Soaking, ASTM E154-Section 8; ASTM E96-Method B: 0.0219 perms.
    - e. Water-Vapor Permeance, Resistance to Plastic Flow and Elevated Temperatures, ASTM E154-Section 11, ASTM E96-Method B: 0.0197 perms.
    - f. Water-Vapor Permeance, Effect Low-Temperature and Flexibility, ASTM E154, Section 12; ASTM E96-Method B: 0.0212 perms.
    - g. Water-Vapor Permeance Resistance to Deterioration from Organisms and Substances in Contacting Soil, ASTM E154-Section 13; ASTM E96-Method B: 0.0198 perms.
    - h. Radon Transmittance (m/s) K124/02/95:  $3.7 \times 10^{-8}$ .
    - i. Radon Coefficient (m<sup>2</sup>/s):  $9.4 \times 10^{-12}$ .
  - 2. Proprietary-Based Specification:
    - a. PERMINATOR 10-mil by W. R. MEADOWS.

**2.03 ACCESSORIES**

- A. High density polyethylene tape with pressure sensitive adhesive: PERMINATOR TAPE by W.R. Meadows.
- B. Primer-adhesive: MEL-PRIME by W. R. MEADOWS.
- C. Pipe collars fabricated from PERMINATOR 10-mil [vapor] [gas] retarder and PERMINATOR TAPE by W. R. MEADOWS.
- D. Fluid-applied waterproofing for closely spaced penetration clusters: MEL-ROL LM or MEL-ROL LM LIQUID MEMBRANE Two-Component by W. R. MEADOWS.
- E. Termination bar: TERMINATION BAR by W. R. MEADOWS.

**PART 3 EXECUTION**

**3.01 EXAMINATION**

- A. Examine substrates to receive the membrane retarder system are deemed appropriate in accordance with manufacturer's current technical literature. Notify architect if substrates are not acceptable. Do not begin the Work until unacceptable conditions have been corrected.

**3.02 SURFACE PREPARATION**

- A. Prepare substrates in accordance with manufacturer's instructions and ASTM E1643. Reference ACI 302.1R-04, Chapter 4, Section 4.1.4 prior to installation of membrane retarder system.
- B. Remove surface rust, scale, oils and coatings from metal surfaces to receive pressure sensitive tape. Apply primer-adhesive immediately after and allow to tack up before placing pressure sensitive adhesive tape.

### 3.03 INSTALLATION

- A. Install the membrane retarder in accordance with manufacturer's instructions and ASTM E 1643.
- B. Unroll membrane retarder with the long dimension parallel with the direction of the placement of the concrete.
- C. Lap membrane retarder over footings and seal to foundation walls. Position membrane retarder snug to all vertical pipe penetrations.
- D. Overlap all lateral and end joints 6 inches (152 mm) and seal with manufacturer's pressure sensitive tape.
- E. Seal all penetrations, including pipes, with manufacturer's pressure sensitive tape and pipe collar fabricated from the specified 15-mil membrane retarder.
  - 1. Cut a minimum 12-inch (304 mm) wide section by one and a half the pipe circumference with 10-mil membrane retarder. Cut "fingers" one half the width of the section.
  - 2. Wrap non-cut half of pipe collar onto pipe. Apply "fingers" of collar onto surrounding 10-mil membrane retarder.
  - 3. Completely tape pipe collar to pipe and surrounding 10-mil membrane retarder in accordance with this specification, manufacturer's technical data sheet and installation guidelines.

Specifier Notes: Where pipe penetrations are clustered too close together, use of cold fluid-applied waterproofing accessory applied around the pipes and onto surrounding membrane is advised.

- F. Repair damaged areas with patch sections of the specified membrane retarder. Apply patch sections over compromised areas. Extend 6 inches (152 mm) beyond the damaged onto surrounding membrane. Tape all sides of patch with pressure sensitive tape.

### 3.04 PROTECTION

- A. Protect and prevent membrane retarder from physical damage until placement of concrete.
- B. Keep UV exposure to no more than 60 days.

END OF SECTION

**BELOW-GRADE VAPOR RETARDERS**

SECTION 07 26 16

SECTION 03 00 00

**BELOW-GRADE GAS RETARDERS**

SECTION 07 26 23

SECTION 03 00 00

Specifier Notes: This guide specification is written according to the Construction Specifications Institute (CSI) MasterFormat. The section must be carefully reviewed and edited by the architect or engineer to meet the requirements of the project. Coordinate this section with other specification sections and the drawings.

Specifier Notes: PERMINATOR 15-mil below-grade [vapor] [gas] retarder is a new generation of a polyolefin-based resin-chemical technology providing enhanced puncture resistance. PERMINATOR 15-mil performs as a water-vapor, methane and radon retarding membrane for underslab conditions. The specifier shall edit this specification to reflect the end use of PERMINATOR 15-mil as either a water vapor retarder **or** a below-grade radon and methane gas retarder based on the above-referenced MasterFormat Sections. Additionally, the specifier shall select the MasterFormat Section Number based on their location preference within the project documents. When specified in 07 26 16 and 07 26 23, coordination with Concrete specifications and drawings is recommended. Manufacturer's technical data sheets, standard details, Installation Guidelines and technical bulletins shall supplement the information contained herein.

## PART 1 GENERAL

## 1.01 SECTION INCLUDES

- A. Surface preparation.
- B. Application of an underslab membrane [vapor] [gas] retarder system.

## 1.02 RELATED SECTIONS

Specifier Notes: Edit the list of Related Sections as required for the project. Include additional sections for Work directly related to or connected with this specification.

- A. Section 03 30 00 – Cast-in-Place Concrete.
- B. Section 07 13 26 - Self-Adhering Sheet Waterproofing.
- C. Section 07 14 16 - Cold Fluid-Applied Waterproofing.
- D. Section 09 64 00 - Wood Flooring.
- E. Section 09 65 00 - Resilient Flooring.
- F. Section 31 20 00 Earth Moving.

## 1.03 REFERENCES

- A. ACI 302.2R - Concrete Slabs that Receive Moisture-Sensitive Flooring Materials—Guide.
- B. ASTM D1709 - Standard Test Methods for Impact Resistance of Plastic Film by the Free-Falling Dart Method.
- C. ASTM E96 - Standard Test Methods for Water Vapor Transmission of Materials.
- D. ASTM E154 - Standard Test Methods for Water Vapor Retarders Used in Contact with Earth Under Concrete Slabs, on Walls, or as Ground Cover.

07 26 16-1

Below-Grade [Vapor] [Gas] Retarders

- E. ASTM E1643 - Standard Practice for Selection, Design, Installation, and Inspection of Water Vapor Retarders Used in Contact with Earth or Granular Fill Under Concrete Slabs.
- F. ASTM E1745 - Standard Specification for Plastic Water Vapor Retarders Used in Contact with Soil or Granular Fill Under Concrete Slabs.
- G. ASTM F1249 - Standard Test Method for Water Vapor Transmission Rate Through Plastic Film and Sheeting Using a Modulated Infrared Sensor.
- H. K124/02/95 - Determination of Radon Transmittance.

1.04 SUBMITTALS

- A. Comply with Section 01 33 00 - Submittal Procedures.
- B. Submit manufacturer's product data and application instructions.

1.05 QUALITY ASSURANCE

- A. Use an experienced installer and adequate number of skilled personnel who are thoroughly trained and experienced in the application of the membrane retarder system.
- B. Obtain membrane retarder materials from a single manufacturer regularly engaged in manufacturing the product.
- C. Provide products which comply with all state and local regulations controlling use of volatile organic compounds (VOCs).

1.06 PRECONSTRUCTION MEETING

- A. Preconstruction Meeting: Convene [one] [ ] week prior to commencing Work of this section, in accordance with Section [XX XX XX] - Project Meetings, and Section [XX XX XX] – membrane [vapor] [gas] retarder system.
- B. Review peripheral system tie-in conditions unrelated to the membrane retarder system and confirm compatibility of all connecting systems. Ensure all peripheral systems are connected in a fully adhered manner.

1.07 MOCKUPS

- A. Prior to start of the Work, apply membrane retarder system in accordance with manufacturers current technical data sheets, specifications, installation guidelines and details to demonstrate correct lapping and sealing to protrusions, adjoining construction and other termination conditions.
- B. Apply a typical 8 foot long by 8-foot wide (2.4 meters by 2.4 meters) representation of the membrane retarder system onto correctly prepared substrate, incorporating connections and interfaces with the following: MEP penetrations, vertical foundations and adjacent constructions. At architect's discretion, the mockup may be incorporated into the Work.

1.08 DELIVERY, STORAGE, AND HANDLING

- A. Deliver materials to project site in manufacturer's original, unopened packaging, with labels clearly identifying the manufacturer and product name.
- B. Store materials in a clean, dry area in accordance with manufacturer's instructions.
- C. Protect materials during handling and application to prevent damage or contamination.

1.09 ENVIRONMENTAL REQUIREMENTS

07 26 16-2 Below-Grade [Vapor] [Gas] Retarders

- A. Product is not intended for conditions subject to abuse or permanent exposure to the elements.
- B. Do not apply on frozen ground.

**PART 2 PRODUCTS**

**2.01 MANUFACTURER**

- A. W. R. MEADOWS, INC., PO Box 338, Hampshire, Illinois 60140-0338. (800) 342-5976. (847) 683-4500. Fax (847) 683-4544. Web Site [www.wrmeadows.com](http://www.wrmeadows.com).

**2.02 MATERIALS**

- A. 15- Mil Plastic [Vapor] [Gas] Retarder
  - 1. Below-grade [vapor] [gas] retarder manufactured of a new generation of polyolefin-based resin-chemical technology having the following properties:
    - a. Water-Vapor Permeance, ASTM E96: 0.0063 perms.
    - b. Puncture Resistance, ASTM D1709, Method B: greater than 3200 grams.
    - c. Tensile Strength, ASTM E154, Section 9: 70 lb./Force/in. (12.26 kN/m).
    - d. Water-Vapor Permeance, After Wet-Out/Dry-Out and Long-Term Soaking, ASTM E154-Section 8; ASTM E96-Method B: 0.0052 perms.
    - e. Water-Vapor Permeance, Resistance to Plastic Flow and Elevated Temperatures, ASTM E154-Section 11, ASTM E96-Method B: 0.0067 perms.
    - f. Water-Vapor Permeance, Effect Low-Temperature and Flexibility, ASTM E154, Section 12; ASTM E96-Method B: 0.0052 perms.
    - g. Water-Vapor Permeance Resistance to Deterioration from Organisms and Substances in Contacting Soil, ASTM E154-Section 13; ASTM E96-Method B: 0.0052 perms.
    - h. Radon Transmittance (m/s) K124/02/95:  $8.7 \times 10^{-9}$ .
    - i. Radon Coefficient (m2/s):  $3.3 \times 10^{-12}$ .
  - 2. Proprietary-Based Specification:
    - a. PERMINATOR 15-mil by W. R. MEADOWS.

**2.03 ACCESSORIES**

- A. High density polyethylene tape with pressure sensitive adhesive: PERMINATOR TAPE by W.R. Meadows.
- B. Primer-adhesive: MEL-PRIME by W. R. MEADOWS.
- C. Pipe collars fabricated from PERMINATOR 15-mil [vapor] [gas] retarder and PERMINATOR TAPE by W. R. MEADOWS.
- D. Fluid-applied waterproofing for closely spaced penetration clusters: MEL-ROL LM or MEL-ROL LM LIQUID MEMBRANE Two-Component by W. R. MEADOWS.
- E. Termination bar: TERMINATION BAR by W. R. MEADOWS.

**PART 3 EXECUTION**

**3.01 EXAMINATION**

- A. Examine substrates to receive the membrane retarder system are deemed appropriate in accordance with manufacturer's current technical literature. Notify architect if substrates are not acceptable. Do not begin the Work until unacceptable conditions have been corrected.

**3.02 SURFACE PREPARATION**

- A. Prepare substrates in accordance with manufacturer's instructions and ASTM E1643. Reference ACI 302.1R-04, Chapter 4, Section 4.1.4 prior to installation of membrane retarder system.
- B. Remove surface rust, scale, oils and coatings from metal surfaces to receive pressure sensitive tape. Apply primer-adhesive immediately after and allow to tack up before placing pressure sensitive adhesive tape.

### 3.03 INSTALLATION

- A. Install the membrane retarder in accordance with manufacturer's instructions and ASTM E 1643.
- B. Unroll membrane retarder with the long dimension parallel with the direction of the placement of the concrete.
- C. Lap membrane retarder over footings and seal to foundation walls. Position membrane retarder snug to all vertical pipe penetrations.
- D. Overlap all lateral and end joints 6 inches (152 mm) and seal with manufacturer's pressure sensitive tape.
- E. Seal all penetrations, including pipes, with manufacturer's pressure sensitive tape and pipe collar fabricated from the specified 15-mil membrane retarder.
  - 1. Cut a minimum 12-inch (304 mm) wide section by one and a half the pipe circumference with 15-mil membrane retarder. Cut "fingers" one half the width of the section.
  - 2. Wrap non-cut half of pipe collar onto pipe. Apply "fingers" of collar onto surrounding 15-mil membrane retarder.
  - 3. Completely tape pipe collar to pipe and surrounding 15-mil membrane retarder in accordance with this specification, manufacturer's technical data sheet and installation guidelines.

Specifier Notes: Where pipe penetrations are clustered too close together, use of cold fluid-applied waterproofing accessory applied around the pipes and onto surrounding membrane is advised.

- F. Repair damaged areas with patch sections of the specified membrane retarder. Apply patch sections over compromised areas. Extend 6 inches (152 mm) beyond the damaged onto surrounding membrane. Tape all sides of patch with pressure sensitive tape.

### 3.04 PROTECTION

- A. Protect and prevent membrane retarder from physical damage until placement of concrete.
- B. Keep UV exposure to no more than 60 days.

END OF SECTION



## INSTALLATION GUIDELINES PERMINATOR®

PERMINATOR underslab vapor barrier/retarder is a new generation of polyolefin-based resin/chemical technology. PERMINATOR's new resin technology allows dramatically greater puncture resistance while maintaining one of the lowest perm ratings in the market. It provides the vapor barrier industry with a highly effective, economical choice for helping to reduce the penetration of moisture and water vapor through the slab into the structure, thereby helping to reduce fungus, mildew, and mold growth. PERMINATOR also helps reduce radon gas from entering the structure.

This document has been created as an addendum to our PERMINATOR technical data sheet to provide information regarding the installation of PERMINATOR. Following are the typical installation instructions recommended by W. R. MEADOWS. It is important to review each application as there may be situations that may require this procedure to be modified based on the project requirements. If this situation arises, please contact W. R. MEADOWS Technical Service.

### INSTALLATION INSTRUCTIONS:

1. Installation of PERMINATOR should be performed in accordance with ASTM E 1643 – Standard Practice for Selection, Design, Installation, and Inspection of Water Vapor Retarders Used in Contact with Earth or Granular Fill Under Concrete Slabs.
2. Level, tamp, or roll earth or granular material beneath the slab base.
3. Unroll PERMINATOR with the longest dimension parallel with the direction of the pour. PERMINATOR should totally cover the area of the pour.
4. Overlap all lateral and end lap joints a minimum of 6" (152 mm) and tape these joints with PERMINATOR

TAPE from W. R. MEADOWS. Roll press the PERMINATOR TAPE to ensure optimum adhesion. Prior to application of the tape, ensure that the area where this is to be applied is free of all dust and contaminants that may affect the adhesion.

### 5. Sealing of PERMINATOR at slab perimeter:

1. Turn the PERMINATOR up the vertical face of the wall approximately the intended thickness of the concrete slab.
2. Apply PERMINATOR TAPE the full length of this termination and roll press into place. Ensure the area is free from any dust or debris that could affect the bond of the tape. In some instances, the concrete may be too dusty to allow for proper adhesion of the tape. If this is the case, apply MEL-PRIME™ adhesive from W. R. MEADOWS onto the concrete, allow it to tack up, and then place PERMINATOR TAPE as above.

### OR

### Sealing of PERMINATOR with foundation wall:

1. Extend PERMINATOR across the top of the footing and turn up the exterior of the wall approximately 12" (304.8 mm) minimum and apply PERMINATOR TAPE along the full length of the termination.
2. Roll press PERMINATOR TAPE into place to ensure proper adhesion. In some instances, the concrete may be too dusty to allow for proper adhesion of the tape. If this is the case, apply MEL-PRIME onto the concrete, allow it to tack up, and then place the PERMINATOR TAPE.
3. Install compatible foundation waterproofing membrane over the pre-applied PERMINATOR. Please refer to W. R. MEADOWS application detail



**W. R. MEADOWS, INC.** | P.O. Box 338 | HAMPSHIRE, IL 60140-0338  
Phone: 847/214-2100 | Fax: 847/683-4544 | [www.wrmeadows.com](http://www.wrmeadows.com)

12/11/23



# INSTALLATION GUIDELINES PERMINATOR®

for specific project requirements.

### Penetration detail procedure for PERMINATOR

1. Cut the material in an "X" pattern and slide over the penetration. Be sure to minimize the size of the cut.

2. Cut an additional piece of PERMINATOR a minimum of 12" (304.8 mm) wide and length being 1.5 times the pipe circumference. With a roofer's knife or scissors, cut "fingers" half the width of the film. See figure below.

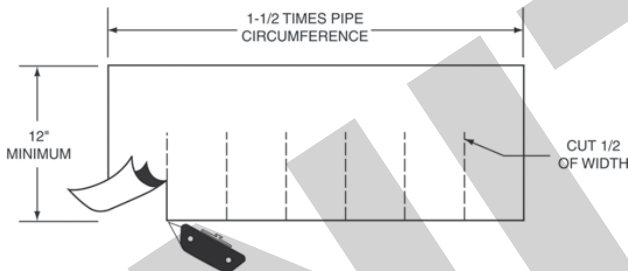

3. Wrap around and tape the collar onto the pipe and completely tape fingers to the bottom layer of PERMINATOR, using PERMINATOR TAPE. See figure below.

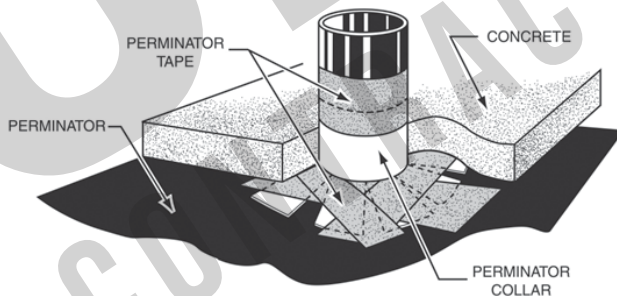

\*In some cases, there will be a cluster of penetrations where the above procedure is not possible. If this is the case, completely fill all voids around the penetrations using MEL-ROL, LM or MEL-ROL LIQUID MEMBRANE (two component) from W. R. MEADOWS.

### Patching procedure for damaged PERMINATOR

#### 1. SMALL HOLES (NAIL PUNCTURES, ETC.)

1. For small holes, apply a piece of PERMINATOR TAPE centered over the hole and roll press into place to ensure full adhesion.

#### 2. LARGE HOLES

1. Cut a piece of PERMINATOR large enough to cover any damage by a minimum overlap of 6" (152.4 mm) in all directions.

2. Clean all adhesion areas of dust, dirt, and moisture.

3. Tape down all edges using PERMINATOR TAPE and roll press tape into place to ensure full adhesion.

Occasionally, it is necessary to drive form stakes through PERMINATOR. An optimum repair would be to apply PERMINATOR TAPE over the hole once stake is removed. Should that not be possible, dip the stake in MEL-ROL LM or MEL-ROL LIQUID MEMBRANE (two component) from W. R. MEADOWS prior to driving it through the membrane. Once the stake is removed, pour enough MEL-ROL LM or MEL-ROL LIQUID MEMBRANE (two component) in the hole to cover it prior to the subsequent concrete pour.



W. R. MEADOWS, INC. | P.O. Box 338 | HAMPSHIRE, IL 60140-0338

Phone: 847/214-2100 | Fax: 847/683-4544 | [www.wrmeadows.com](http://www.wrmeadows.com)



## TECHNICAL BULLETIN

# RADON

### WHAT IS RADON?

Radon is a naturally occurring radioactive gas that is formed by the breakdown of uranium in soil, rock, and groundwater. It is a colorless and odorless gas and moves freely through the soil. In outdoor air, radon is typically not a health concern as it mixes with this outdoor air resulting in very low concentrations. However, in enclosed spaces, such as buildings, it can accumulate resulting in high concentrations. The source of radon is the soil on which the building is constructed and has the ability to enter the building through cracks in foundation walls and floors, and any gaps around pipes and cables. Just because a building doesn't have a basement doesn't mean radon cannot enter. Slab on grade buildings and buildings over crawl spaces are also susceptible. In addition, buildings can create vacuums that can draw radon in through natural causes, such as the stack effect, and also from mechanical causes that can include exhaust fans. Radon is heavier than air, resulting in higher

radon concentrations being detected at lower levels, however, as a result of these vacuums, it is possible that higher concentrations of radon can be detected at higher levels within a building.

### HEALTH RISKS

The known health risk associated with radon exposure is an increased risk of developing lung cancer. Radon is the second leading cause of lung cancer behind smoking. It is a Group A carcinogen and 16% of all lung cancer deaths are attributed to radon exposure. As radon gas breaks down, it releases radon decay products (RDPs) which attach to lung tissue where they breakdown further, releasing alpha particles. These alpha particles are absorbed by this lung tissue resulting in lung cell death, or damage/mutations leading to lung cancer.

In 2003, the EPA had updated estimations of lung cancer risks as a result of indoor exposure based on the Biological Effects of Ionizing Radiation (BEIR) VI Report (1999) report. The EPA worked with the Science Advisory Board (SAB) to review and incorporate the risk models in this report and the updated estimations of lung cancer deaths as a result of radon exposure is about 21,000 annually, which was consistent with this BEIR VI report. According to these estimates, about 2,900 of these deaths occur among people who have never smoked.

In 2005, the U.S. Surgeon General published a Health Advisory stating "Indoor radon gas is the second-leading cause of lung cancer in the United States and breathing it over prolonged periods can present a significant health risk to families all over the country. It's important to know that this

### RADON ENTRY POINTS

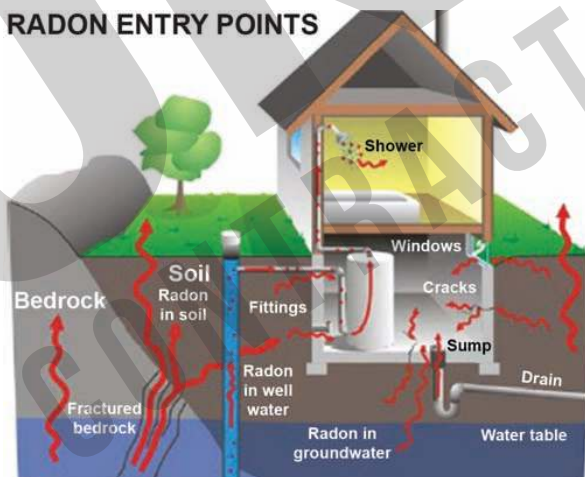

**W. R. MEADOWS, INC.** | P.O. Box 338 | HAMPSHIRE, IL 60140-0338  
Phone: 847/214-2100 | Fax: 847/683-4544 | [www.wrmeadows.com](http://www.wrmeadows.com)

01/17



# TECHNICAL BULLETIN RADON

threat is completely preventable. Radon can be detected with a simple test and fixed through well-established venting techniques.”

## RADON GUIDELINES

The U.S. Environmental Protection Agency has maintained a radon action level of 4 picocuries/litre (pCi/L) since the 1980s. This is equivalent to approximately 148 Bq/m<sup>3</sup>. The EPA notes that concentrations of radon below this level still pose a risk and recommends Americans consider mitigation if radon levels are above 2 pCi/L. In comparison to other guidelines around the world, Canada has a higher allowed exposure guideline of 200 Bq/m<sup>3</sup> which is equal to 5.4 pCi/L, and globally, the World Health Organization recommends 100 Bq/m<sup>3</sup> (2.7 pCi/L).

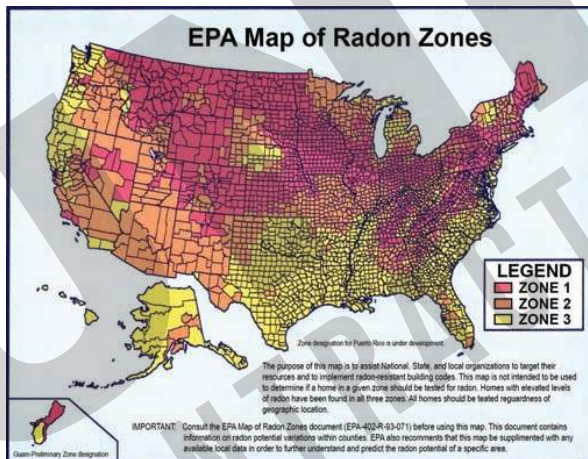

- Zone 1: Counties with predicted average indoor radon screening levels greater than 4 pCi/L
- Zone 2: Counties with predicted average indoor radon screening levels from 2 to 4 pCi/L
- Zone 3: Counties with predicted average indoor radon screening levels less than 2

## TESTING

This can be done by purchasing a do-it-yourself radon test kit, or it can be performed by a radon measurement professional, certified under the National Radon Proficiency Program (NRPP).

To provide a realistic estimate of the radon concentrations, the measurements should be made in the normal occupancy area of the lowest lived-in level of the house. This is defined as an area occupied by an individual for more than 4 hours a day and can include spaces such as living rooms or bedrooms.

The two most common types of radon detectors used for testing buildings are short term and long term detectors. The short term detectors are used for a period of 2-7 days, the long term detectors can be used for a period of 1 to 12 months. Since the radon concentration inside a building can vary over time, a longer period of testing will give a more accurate level of radon concentration. Health Canada recommends a test period of 3 months minimum. It also recommends that the ideal time of the year is between September and April when windows and doors are typically kept closed.

## MIGRATION TECHNIQUES

### Radon Resistant Construction Techniques

As building codes and standards continue to develop to establish minimum construction standards for radon resistant construction, techniques have currently been established for existing and new construction to provide protection against radon gas infiltration.



**W. R. MEADOWS, INC.** | P.O. Box 338 | HAMPSHIRE, IL 60140-0338  
 Phone: 847/214-2100 | Fax: 847/683-4544 | [www.wrmeadows.com](http://www.wrmeadows.com)



## TECHNICAL BULLETIN

# RADON

There are two types of depressurization systems that have been deemed effective, passive and active. A passive system is one where the installed pipe is used along with the natural ventilation to allow movement of the radon to the outside of the building. If this is not effective in reduction below the guideline, then an active system is required to be installed.

### EXISTING CONSTRUCTION

In an existing structure, if the radon levels are found to be in excess of the guideline, the most common method for radon reduction is active soil depressurization (ASD). This involves the drilling of a hole in the concrete floor slab, installation of a pipe with a fan that will draw the radon gas from under the building and force it outside. The installation of this system is typically performed by a contractor certified by NRPP.

### NEW CONSTRUCTION

Use a clean coarse granular material below the floor slab to allow the gases to move freely underneath the building. Granular material shall be a minimum of 4 inches thick and shall consist of material that will pass through a 2-inch sieve and be retained by a 1/4-inch sieve. Alternatively, a uniform layer of sand can be used, a minimum of 4 inches thick, overlain by a layer or strips of geotextile drainage matting designed to allow the lateral flow of soil gases.

Seal all openings, penetrations, and cracks in the concrete foundation floor (including the perimeter), and walls with sealant to prevent radon from entering the building.



**W. R. MEADOWS, INC.** | P.O. Box 338 | HAMPSHIRE, IL 60140-0338  
Phone: 847/214-2100 | Fax: 847/683-4544 | [www.wrmeadows.com](http://www.wrmeadows.com)

Install a soil gas/vapor retarder membrane on top of the gravel to prevent soil gases from entering the building. It is imperative that this material be of sufficient strength to resist puncture and maintain the integrity of the soil gas barrier. Seal all overlap, joints, and terminations of this membrane to provide a continuous barrier.

Run a 3" minimum PVC pipe vertically from the gravel layer under the floor slab, vertically through the concrete floor slab, and terminate at least 12 inches above the surface of the roof, in a location at least 10 feet away from any window or other opening into the conditioned spaces of the building that is less than 2 feet below the exhaust point, and 10 feet from any adjoining or adjacent buildings.

To facilitate installation of an active sub-slab depressurization system, electrical junction boxes shall be installed during construction in proximity to the anticipated locations of vent pipe fans and system failure alarms.

Building is to be positively pressurized (especially areas adjacent to walls, floors and roofs in contact with the soil) when all ventilation and exhaust systems are operational.

Long term testing of building is needed, and if the radon concentration levels exceed the guideline, installation of a full active soil depressurization system would be required.

The above information has been developed to provide an overview of radon, the effects that it has on our population, as well as the current techniques being used to measure the radon concentration and construction methods to be



## TECHNICAL BULLETIN RADON

able to control the exposure to radon within in a building. Radon mitigation systems require a soil gas barrier and current new construction requirements do allow a polyethylene sheet to be used. It has been shown that standard polyethylene can have a relatively low puncture resistance, as well as having the potential to degrade when in contact with the soil, both characteristics causing the gas barrier to be discontinuous. W. R. MEADOWS manufactures PERMINATOR® and PRECON underslab barriers that have superior puncture resistance and have been designed and tested to meet the industry standards for underslab construction. In addition, these products have been tested for radon resistance and can be part of an effective radon mitigation system. For information on how W. R. MEADOWS can contribute to a radon mitigation system, please visit our website at [www.wrmeadows.com](http://www.wrmeadows.com), or contact your local technical representative.



**W. R. MEADOWS, INC.** | P.O. Box 338 | HAMPSHIRE, IL 60140-0338  
Phone: 847/214-2100 | Fax: 847/683-4544 | [www.wrmeadows.com](http://www.wrmeadows.com)

01/17

**W. R. MEADOWS, INC.**

P.O. Box 338 • Hampshire, IL 60140-338  
 www.wrmeadows.com • wrmil@wrmeadows.com



TELEPHONE: 847-214-2100  
 800-825-5976  
 FAX: 847-683-4544

September 3, 2025

W. R. MEADOWS certifies the following information for PERMINATOR® 10 and 15 Mil Underslab Vapor Barrier:

**LEED v4.0/4.1 MRC3: BPDO – Sourcing of Raw Materials**

Manufacturing Location: >100 miles  
 Raw Material Extraction Point: Not Available  
 Recycled Content: 0%

**LEED v4.0/4.1 EQc2: Low Emitting Materials**

VOC Emissions: This product is classified as part of the building's exterior and is not subject to CDPH VOC emissions from indoor sources test requirements.

VOC Content: This is not a wet-applied product, and therefore, this testing does not apply.

If field sampling and/or field or laboratory testing are required, W. R. MEADOWS cannot be held responsible for any cost incurred if this product is used prior to receipt of that approval.

Should you have any questions or require additional information, please feel free to contact Technical Services or your local W. R. MEADOWS Representative.

Sincerely,

Kimberly Ann Lombardozi, LEED AP ID+C, WELL AP, fitwel Ambassador  
 Sustainability Manager  
 W. R. MEADOWS, INC.

ENVIRONMENTALLY RESPONSIBLE CONCRETE PERFORMANCE PRODUCTS