



MasterFormat:
03 33 00
07 26 16

MARCH 2025
(Supersedes March 2024)

PERMINATOR®

15 Mil Underslab Vapor Barrier

DESCRIPTION

PERMINATOR underslab vapor barrier is a new generation of polyolefin-based resin/chemical technology. PERMINATOR provides the vapor barrier industry with a highly effective, economical choice for helping to reduce the penetration of moisture and water vapor through the slab into the structure, thereby helping to reduce fungus, mildew, and mold growth. PERMINATOR also helps reduce radon gas from entering the structure.

New resin technology allows dramatically greater puncture resistance while maintaining one of the lowest perm ratings in the market.

PERMINATOR is tough enough to withstand normal construction jobsite conditions and traffic. It will not crack, puncture, snag, split, or tear easily.

PERMINATOR prevents uncontrolled moisture from entering the slab allowing the slab to maintain the maximum slab moisture emission rate and relative humidity level as allowed by flooring manufacturer's specifications.

Installation is quick and easy. All joints/seams, both side and end, should be overlapped 6" (152.4 mm) and taped using 4" (101.6 mm) wide PERMINATOR TAPE from W. R. MEADOWS. PERMINATOR rolls fast and smoothly over level tamped soil or compacted fill.

USES

PERMINATOR underslab vapor barrier is primarily designed for underslab construction, where the soil has been tamped and leveled or compacted fill has been applied. Sheets are unrolled as is or cut to size and installed using the overlapping method. Overlaps are 6" (152.4 mm) wide and these seams are sealed using 4" (101.6 mm) wide PERMINATOR TAPE.

PERMINATOR can also be used as a protection course for waterproofing membranes. The desired sheet lengths are cut to size and retained at the top of the waterproofing membranes by PERMINATOR TAPE or TERMINATION BAR from W. R. MEADOWS. The product can also be used in crawlspace applications.

FEATURES/BENEFITS

- Helps reduce the penetration of moisture and water vapor through the slab into the structure.
- Helps reduce fungus, mildew, and mold.
- Helps reduce radon gas from entering a structure.
- Resistant to methane gas.
- Tough enough to withstand normal construction jobsite conditions and traffic ... will not crack, puncture, snag, split, or tear easily.
- Installs quickly and easily over tamped grade ... no gravel, fill, or sand needed.
- PERMINATOR prevents uncontrolled moisture from entering the slab allowing the slab to maintain the maximum slab moisture emission rate and relative humidity level as allowed by flooring manufacturer's specifications.
- 15 mil thickness clearly marked on membrane for easy visual identification on jobsite.
- VOC content is 0 g/L.
- Made in America.

PACKAGING

14' (4.3 m) wide, 140' (42.7 m) long rolls

*Factory welds are available by special order if larger width rolls are required.

SPECIFICATIONS/STANDARDS

- Meets or exceeds all requirements of ASTM E1745 Class A, B & C.
- ACI 302.2R: Guide for Concrete Slabs that Receive Moisture Sensitive Flooring Materials makes a suggestion to use materials having 0.01 perms when flooring materials require protection lower than that determined by ASTM E1745. PERMINATOR 15 mil meets this requirement.

CONTINUED ON REVERSE SIDE ...

W. R. MEADOWS, INC.

P.O. Box 338 • Hampshire, IL 60140-0338
Phone: 847/214-2100 • Fax: 847/683-4544
1-800-342-5976
www.wrmeadows.com • info@wrmeadows.com

HAMPSHIRE, IL / CARTERSVILLE, GA / YORK, PA
FORT WORTH, TX / BENICIA, CA / POMONA, CA
GOODYEAR, AZ / MILTON, ON / SHERWOOD PARK, AB

TECHNICAL DATA

Properties	PERMINATOR (15 mil)
Water Vapor Permeance ASTM E96 Perms	0.0063
Puncture Resistance ASTM D1709 Method B Grams	>3200
Tensile Strength ASTM E154 Section 9 Lb. Force/Inch (kN/m)	72 (12.61)
Water Vapor Permeance After Wetting Out Drying Out and After Long-Term Soaking ASTM E154 Section 8 ASTM E96 Procedure B Perms	0.0052
Water Vapor Permeance Resistance to Plastic Flow and Elevated Temperature ASTM E154 Section 11 ASTM E96 Procedure B Perms	0.0057
Water Vapor Permeance Effect Low Temperature and Flexibility ASTM E154, Section 12 ASTM E96, Procedure B Perms	0.0052
Water Vapor Permeance Resistance to Deterioration From Organisms and Substances in Contacting Soil ASTM E154, Section 13 ASTM E96 Procedure B Perms	0.0052
Radon Transmittance (m/s), k124/02/95	8.7×10^{-9}
Radon Coefficient (m ² /s)	3.3×10^{-12}

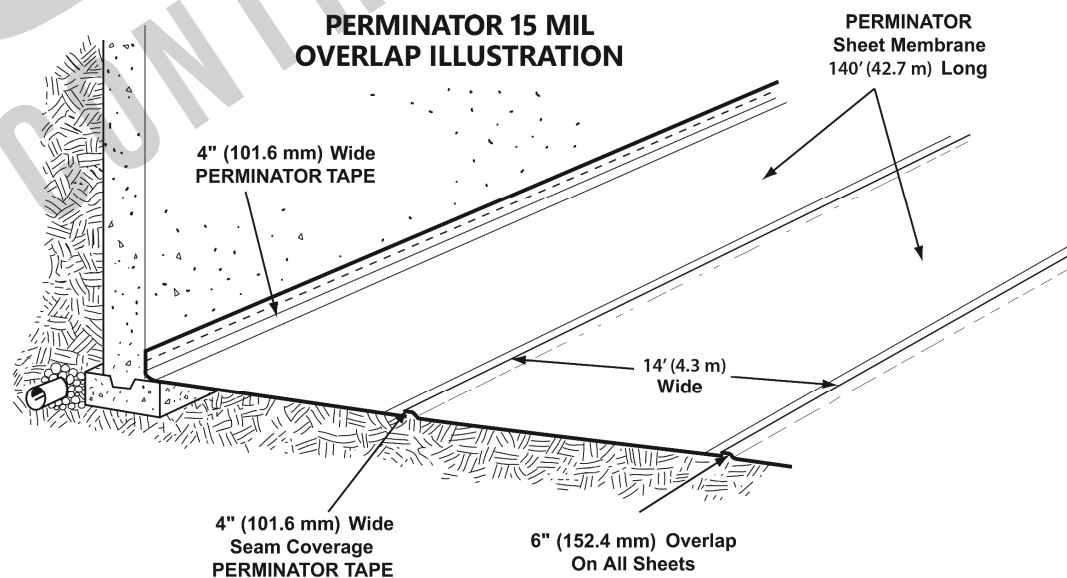

APPLICATION

Surface Preparation ... Level, tamp, or roll earth or granular material beneath the slab base as specified by supplied architectural drawings. Follow ASTM E-1643-10 (standard practice and procedure for installation of vapor retarder used in contact with earth or fill under concrete slabs). Reference American Concrete Institute (ACI) 302.1R-04: Chapter 4, Section 4.1.4 – Base Material for sub-grade preparation prior to placement of PERMINATOR. (ACI) 302.1R-04: Chapter 4, Section 4.1.4 – Base Material for sub-grade preparation prior to placement of PERMINATOR.

Horizontal Application ... Unroll PERMINATOR over the area where the slab is to be poured. Cut to size if necessary. PERMINATOR should completely cover the pour area. All joints/seams, both side and end, should be overlapped 6" (152.4 mm) and taped using 4" (101.6 mm) wide PERMINATOR TAPE. (Note: The PERMINATOR TAPE area of adhesion should be free from dust, dirt, and moisture to allow maximum adhesion of the pressure-sensitive tape.)

The most efficient installation method includes placing PERMINATOR on top of the footing and against the vertical wall. This will sandwich PERMINATOR between the footing, vertical wall, and poured concrete floor. (See illustration on page 2.) This will help protect the concrete slab from external moisture sources once the slab has been placed.

Before placing concrete slab, make sure all penetrations, block outs, and damaged areas are repaired/addressed.

Numerous municipal building codes do not allow the placement of vapor barriers over the footing, due to breaking of the bond between the wall and footing. Although this is not an optimal application method, W. R. MEADOWS approves this alternate method when required by building code.

Figure 1 COLLAR

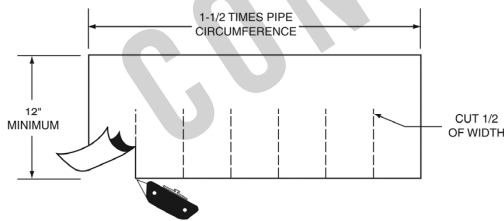

Seal All Protrusions ... Cut a slit around pipes, ductwork, rebar, and wire penetrations to place the initial layer of PERMINATOR. To further protect the concrete slab from external moisture sources, use a piece of PERMINATOR and place a collar around this as well.

1. Cut a piece of PERMINATOR a minimum width of 12" (304.8 mm). The length should be 1.5 times the pipe circumference. With a roofer's knife or scissors, cut "fingers" half the width of the film. See Figure 1.

2. Wrap around and tape the collar onto the pipe and completely tape fingers to the bottom layer of PERMINATOR, as shown in Figure 2.

In the event that PERMINATOR is damaged during or after installation, repairs must be made. Cut a piece of PERMINATOR large enough to cover any damage by a minimum overlap of 6" (152.4 mm) in all directions. Clean all adhesion areas of dust, dirt, and moisture. Tape down all edges using PERMINATOR TAPE.

NOTE: It is not necessary to overlay PERMINATOR with gravel or sand. PERMINATOR is tough enough to withstand normal construction abuse and traffic. Most flooring companies recommend the placement of the concrete slab directly on the vapor barrier. We agree, since this eliminates the potential for trapping moisture in a blotter-effect, causing it to resurface through the slab into the flooring systems. Consult local building codes and regulations, plus architectural and design firm guidelines, prior to application.

Figure 2: COLLAR INSTALLATION

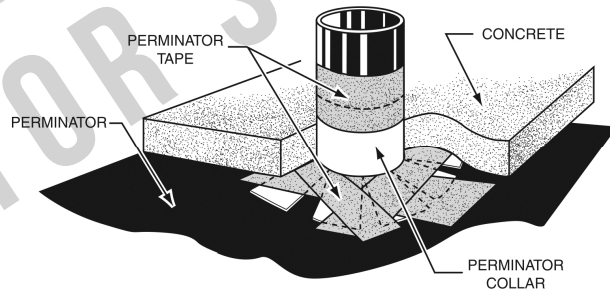

Vertical Wall Application ... Install MEL-ROL® waterproofing membrane or MEL-ROL LM liquid waterproofing membrane from W. R. MEADOWS according to installation instructions. While the membrane is still tacky, install PERMINATOR as a protective course over the applied waterproofing membrane. Using TERMINATION BAR with concrete nails or PERMINATOR TAPE at the termination of the waterproofing membrane is advisable in some applications. Supervised care must be taken during backfilling against the material so that it is not damaged or punctured. If damage occurs, patch using the techniques outlined previously. When applying PERMINATOR TAPE to foundation walls, MEL-PRIME™ adhesive from W. R. MEADOWS may be used to increase bond.

ACCESSORIES

MEL-DRAIN™ rolled matrix drainage system is designed to remove moisture from around footings and to relieve hydrostatic head pressures. Several different versions are available.

MEL-ROL LM or POINTING MASTIC may be used for stakes, small pipe, and rebar penetrations. Cut PERMINATOR just big enough for the penetration. Liberally apply MEL-ROL LM or POINTING MASTIC around the penetration to keep the integrity of the PERMINATOR membrane intact. MEL-ROL LM can be applied by brush, roller, or sprayer. POINTING MASTIC can be applied by caulking gun or trowel.

PERMINATOR TAPE is a self-adhesive tape for use in sealing vapor barrier seams and attachment to footings, protrusions, etc. It is offered in 4" (10 cm) widths and roll lengths of 180' (55 m)/roll. It is packaged twelve rolls per carton. Coverage: One box of tape will adhere approximately 10 rolls of PERMINATOR.

TERMINATION BAR is provided in 10' (3 m) lengths to attach PERMINATOR to walls as a protection course for vertical surface waterproofing applications.

PRECAUTIONS

PERMINATOR underslab vapor barrier does not negate the need for relief of hydrostatic heads. A complete drain tile system should be placed on the exterior of the footing and, in severe cases, on the interior of the footing as well. For maximum concrete performance and durability, the concrete floor slab design should provide for the lowest possible slump, yet assure complete hydration of the concrete. Refer to Safety Data Sheet for complete health and safety information.



LIMITED WARRANTY

W. R. MEADOWS, INC. warrants at the time and place we make shipment, our material will be of good quality and will conform with our published specifications in force on the date of acceptance of the order. Read complete warranty. Copy furnished upon request.

Disclaimer

The information contained herein is included for illustrative purposes only, and to the best of our knowledge, is accurate and reliable. W. R. MEADOWS, INC. cannot however under any circumstances make any guarantee of results or assume any obligation or liability in connection with the use of this information. As W. R. MEADOWS, INC. has no control over the use to which others may put its product, it is recommended that the products be tested to determine if suitable for specific application and/or our information is valid in a particular circumstance. Responsibility remains with the architect or engineer, contractor and owner for the design, application and proper installation of each product. Specifier and user shall determine the suitability of products for specific application and assume all responsibilities in connection therewith.

© W. R. MEADOWS 2024